

**PLAN VIEW**

Weight of Item

**1320 Kilo**

Application & Uses

**Drainage  
Electrical  
Sewerage  
Communication**



Quality Drainage Products

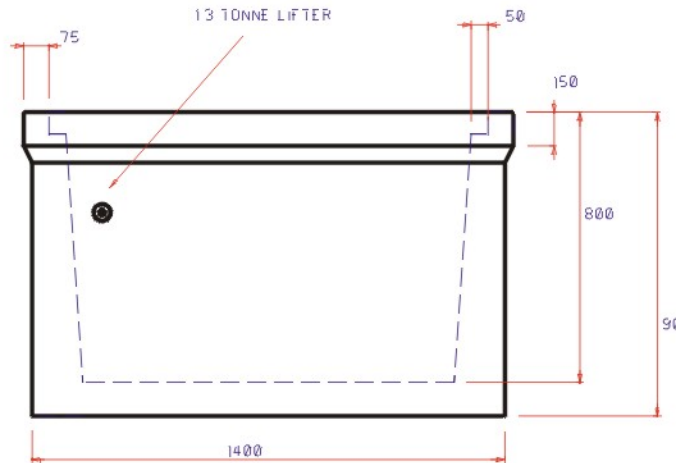

**FRONT VIEW**

**600 Max Pipe**

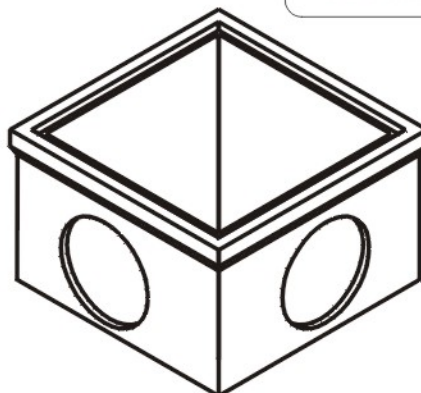

**ISOMETRIC VIEW**

**All WILMAC products are manufactured to comply with the published Australian Standard relating to the application for which they are intended.**

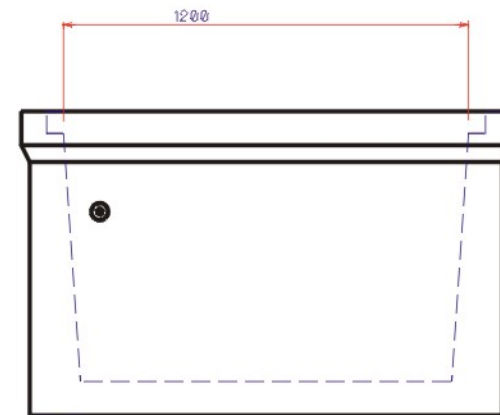

**SIDE VIEW**

Description of Item

**1200x1200x800 Pit Base**

Product Code

**128P**

**WILMAC PTY LTD**

ABN 39 002 205 969  
40 Burrabogee Road Pendle Hill NSW  
phone(02) 9631 0957 fax: (02) 9636 3715  
email: sales@wilmac.com.au