

TOP VIEW

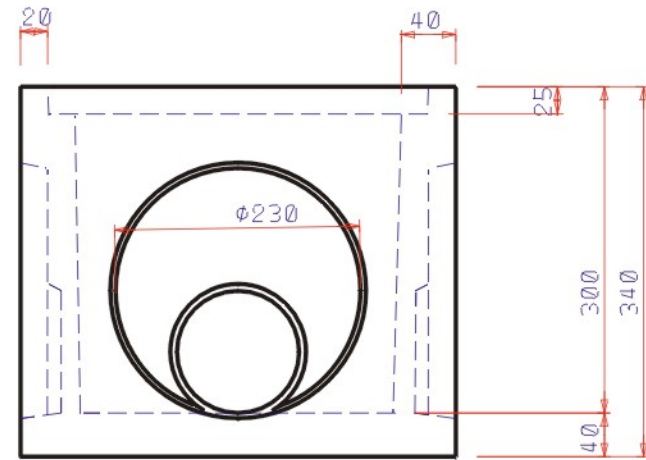

FRONT VIEW

Weight of Item

40 Kilo

Application & Uses

**Drainage
Electrical
Sewerage
Communication**

150 Max Pipe

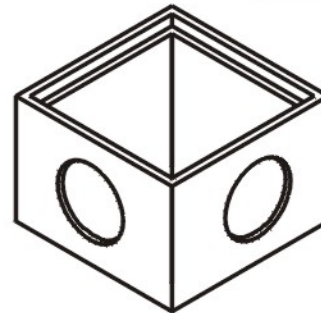

ISOMETRIC VIEW

Description of Item

300x300x300 Pit Base

Product Code

333P

WILMAC PTY LTD

ABN 39 002 205 969

40 Burrabogee Road Pendle Hill NSW
phone(02) 9631 0957 fax: (02) 9636 3715
email: sales@wilmac.com.au

All WILMAC products are manufactured to comply with the published Australian Standard relating to the application for which they are intended.



Quality Drainage Products