

TOP VIEW

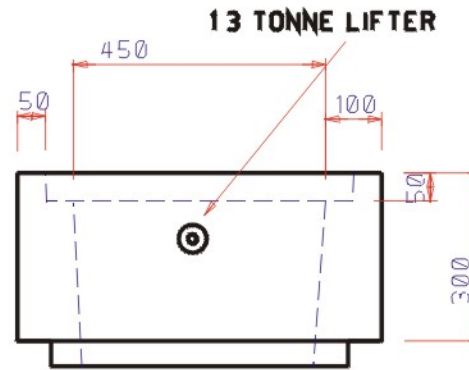

300 RISER

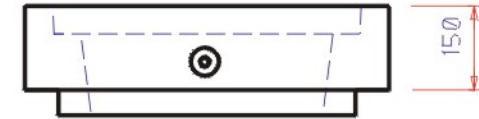

150 RISER

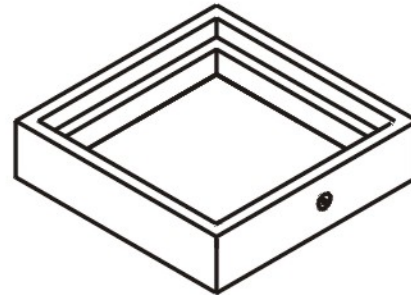

ISOMETRIC VIEW

Weight of Item

**90 Kilo**

Application & Uses

**Drainage  
Electrical  
Sewerage  
Communication**



Quality Drainage Products

**All WILMAC products are manufactured to comply with the published Australian Standard relating to the application for which they are intended.**

Description of Item

**450x450x150 Riser**

Product Code

**551R**

**WILMAC PTY LTD**

ABN 39 002 205 969

40 Burrabogee Road Pendle Hill NSW  
phone(02) 9631 0957 fax: (02) 9636 3715  
email: sales@wilmac.com.au