

TOP VIEW

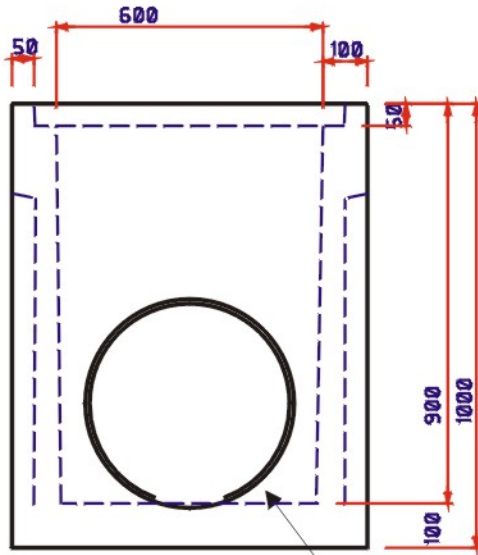

FRONT VIEW

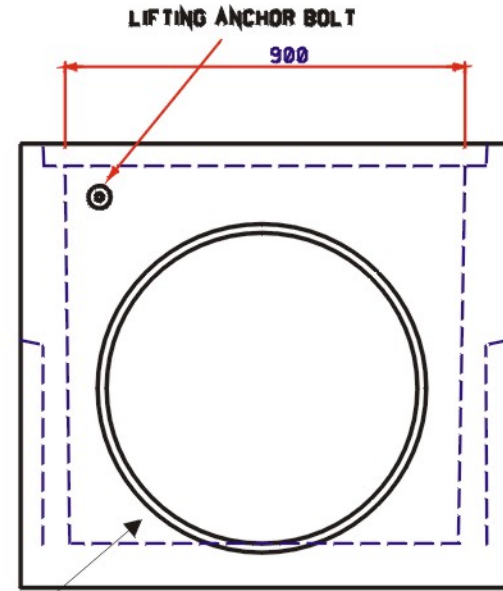

FRONT VIEW

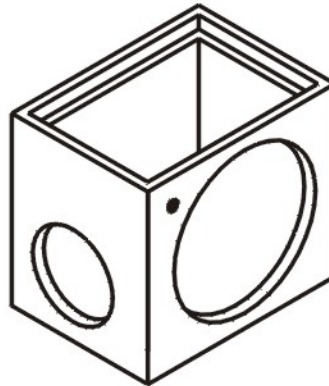

ISOMETRIC VIEW

450 - 600 Max. Pipe

Weight of Item

770 Kilo

Application & Uses

**Drainage
Electrical
Sewerage
Communication**

Description of Item

900x600x900 Pit Base

Product Code

969P

WILMAC PTY LTD

ABN 39 002 205 969

40 Burrabogee Road Pendle Hill NSW
phone(02) 9631 0957 fax: (02) 9636 3715
email: sales@wilmac.com.au

All WILMAC products are manufactured to comply with the published Australian Standard relating to the application for which they are intended.



Quality Drainage Products